

New Zealand Association of Radio Transmitters



Christchurch Branch Inc.

GALBRAITH
PROJECTS

P.O. BOX 1733
CHRISTCHURCH

144-148 MHz 30 WATT RF POWER AMPLIFIER.

T.J. Laughton ZL3TJX

INTRODUCTION.

A compact RF power amplifier has been developed. Operating from a thirteen volt supply, this amplifier is capable of boosting the one half to two Watts produced by most two-metre band handhelds to a maximum level of around thirty Watts.

The design objectives at the outset of this project were :-

- 1 To produce a compact twelve volt power amplifier to boost the output power of two-metre handhelds to around twenty Watts.
- 2 To maximise the efficiency of such an amplifier for portable operation.
- 3 To produce an amplifier with performance comparable to commercial designs especially in the areas of stability and ruggedness.
- 4 To produce a non-critical design at minimum cost which can be reproduced reliably from kit form without elaborate test gear

These objectives were achieved with the design which will now be described.

CHOICE OF RF DEVICE.

Recent developments in RF power devices have been mainly in the area of improving the ruggedness of transistors under load mismatch and voltage and temperature extremes. For several years now, twenty Watt devices have been available with gains around ten dB at VHF. Such a device is the MRF240. Experience has shown such devices to be fragile and can often be damaged during initial tune-up. The current generation of devices however are more rugged than these earlier parts and, are able to withstand large VSWR's at voltage extremes.

Of the devices investigated for this application it was found that the Philips BLW32 showed the best gain and efficiency and was readily available at a competitive price. After ruggedness had been confirmed, the design proceeded around this device.

Philips specify this device as follows :-

RF Performance at $T_a = 25\text{ C}$

Mode	Vce	F	P	Gp	
CW Class B	13.5V	175MHz	28W	>9dB	>60%

It is guaranteed to withstand severe load mismatch conditions with a supply over-voltage to 16.5 Volts.

CIRCUIT DESIGN.

Because of the narrow bandwidth required from this amplifier, simple $n=3$ input and output matching sections were used. The base reactance was tuned out with a 100 pf disk ceramic capacitor spaced a few millimetres back from the package. The collector capacitance was tuned with the collector choke.

To ensure class B operation, a DC short was applied to the base in the form of a choke. This choke is designed to exhibit a low Q at low frequencies to ensure stability.

An $n=3$ low pass section was added to the output section to reduce the harmonic outputs to below 250uW.

Automatic transmit/receiving switching was achieved by sniffing a small amount of the input power to control a changeover relay. The relay used in this design is a cheaper option than PIN diode switching and exhibits lower loss.

ALIGNMENT.

The minimum amount of test gear required to tune-up this amplifier consists of a thirteen volt power supply with a current rating of about four amperes, a 50 ohm dummy load capable of handling 25 or 30 Watts, a VHF VSWR meter or directional power meter, and a two-meter band handheld.

Two tuning adjustments were incorporated into the amplifier design, one in the input matching section, and one in the output matching section. Tune up consists of applying RF power to the input (about 2 watts) and adjusting the output trimmer while monitoring the output power and amplifier current. The input trimmer is then adjusted for minimum VSWR with the VSWR bridge between the handheld and the amplifier. This process may have to be repeated a few times due to a small interaction between the trimmers.

PERFORMANCE.

The measured performance of the authors prototype was as follows :-

Frequency: 146 MHz.

13.8 V.

25 C.

Drive Power (W)	Output Power (W)	Amplifier Current (A)	Gain (dB)	Efficiency (%)
0.5	20	2.2	16	66
1.0	25	2.5	14	72

Stability into a 5:1 VSWR (all phase angles) and ruggedness at voltage and temperature extremes into an infinite VSWR (all phase angles) were confirmed.

A specification for the amplifier follows. Because of the variations in construction techniques which can be expected with a kit of this type, the author can not guarantee the specified performance. If due care is taken however, the specified performance should be readily achieved.

SPECIFICATIONS.

Frequency Range:	144-148 MHz.
Supply Volts:	Standard - 13.8 V. Extreme - 10.8, 16.0 V.
Input Power Range:	0.5 W to 2.0 W.
Input and Output Impedance:	50 Ohms.
Gain:	>10 dB.
Efficiency:	>60 %.
Operating Temperature:	Standard - 25 C Ambient. Extreme - -10 C, + 60 C Ambient.
Input VSWR:	<1.1:1
Duty Cycle:	Continuous operation under voltage and temperature extremes.
Stability:	Stable into 5:1 VSWR (all phase angles) at voltage and temperature extremes.
Ruggedness:	2 minutes into an infinite VSWR (all phase angles) at voltage and temperature extremes.
Spurious Emissions:	<250 uW.
Transmit/Receive Switching:	Input power sense controlled relay

ASSEMBLY INSTRUCTIONS

DO NOT REMOVE THE BNC CONNECTORS.

The BNC Connectors have been sealed in place with Locktight so as to stop them coming loose when the Plugs are twisted on and off.

- Check parts against parts list before starting.*
- (1) First check that the PC Board fits neatly onto the PEM spacers and the BNC connectors on the heatsink if not adjust the holes in the PC board with a small file.
 - (2) Solder two strips of copper track wrapped around the edge of the PC board so as they will fit under the Emitter Tags. Make sure you are left with at least 10mm between the strips of copper.

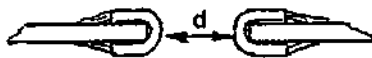

make sure $d > 10\text{mm}$

- (3) Fit clean resistor leads thru PC board as wire thru's where marked solder both top and bottom.
- (4) Fit Relay, Resistors and Capacitors except for the 100pf.
- (5) Wind coils as follows :- All use .8mm Wire. (The larger wire.)

L1 is 2.5 turns on 4mm former.
L2 is 3.5 turns on 4mm former.
L3 is 1.5 turns on 3.5mm former.
L4 is 5.5 turns on 4mm former.
L5 is 1.5 turns on 2.5mm former.

- (6) L6 is 2.5 turns of 0.6mm Enameled Copper Wire through Philips six hole bead.
- (7) Fit coils but LEAVE transistor end of L4 floating.
- (8) Fit coax and BC548, BC327, 1N4148.
- (9) Fit the 153 Auto Cable and arrange for it to leave the unit via the opposite end to the relay.
- (10) At this point it is IMPORTANT to make sure you trim all leads on the bottom of the PC Board very short, so as they will not make contact with the heatsink. A small pair of side cutters is idea for this.
- (11) Screw board in position.
- (12) Fit Galbraith label. The BNC socket nearest the Power Transistor mounting hole is the INPUT socket.
- (13) Cut RF transistor Tags to approx. 8mm's long. NOTE the tag with the angle cut is the Collector, mark this before cutting.

***** WARNING *****

DO NOT SCRATCH OR DAMAGE TRANSISTOR PACKAGE SINCE IT CONTAINS BERILIUM OXIDE WHICH IN POWERED FORM CONSTITUTES A SERIOUS HEALTH RISK.

Tin the underside of the transistor tags smear a small amount of heat sink compound on the transistor base and while aligning the device to the P.C.B. torque down the stud nut ~~to about eight inch pounds~~ *Do not over tighten.*

Solder the tags to the P.C.B.

- (15) Solder the remaining end of L4 to the base of the device. Solder the 100pf capacitor 2.5mm back from the ceramic cap of the device
- (16) Fit Grommet onto power cable and pass through the hole in the cover allow enough lead to form a small fold under cover so as the cover does not get in the way when tuning.
- (17) Fit fuse holder and fuse into the Red power lead.
- (18) Tune up using the instructions. Remember if you do not have 13.8 Volts you may not get the quoted power out.
- (19) Fit cover with two small PK screws.

20 Do not forget to solder BNC connectors. Fil. Feet.

TUNING INSTRUCTIONS

***** DO NOT USE A REPEATER FREQUENCY WHILE ADJUSTING ANY TRANSMITTER *****

- (1) Apply 13.8 volts DC to the unit.
- (2) Connect a 50 ohm load to the output.
- (3) Connect 0.5 to 2 Watt source (ie Handheld) to the input via an S.W.R. bridge.
- (4) Set both trimmers to half capacitance.
- (5) Key up source and tune input for minimum reflected power.
- (6) Place power meter in output and tune output trimmer for max. powerout.
- (7) Repeat 5 and 6
- (8) Check P.A. current drops to zero when drive is removed. If P.A. draws current when drive is removed check construction, load, and tuning. Trimmer positions should both be just past half capacitance.

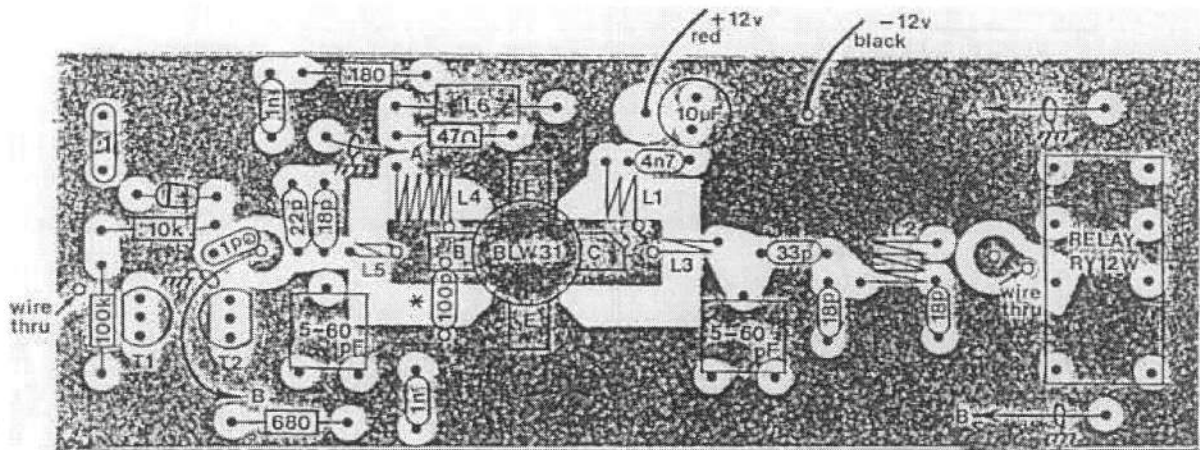

T1 - BC547 • solder on bottom of board
 T2 - BC327 ○ " " top " "

E = emitter tabs
 * read notes

A-A centre conductor of coax.
 B-B " " " "
 solder shields of coaxes as
 close to termination as possible
 centre insulation is Teflon, will not melt

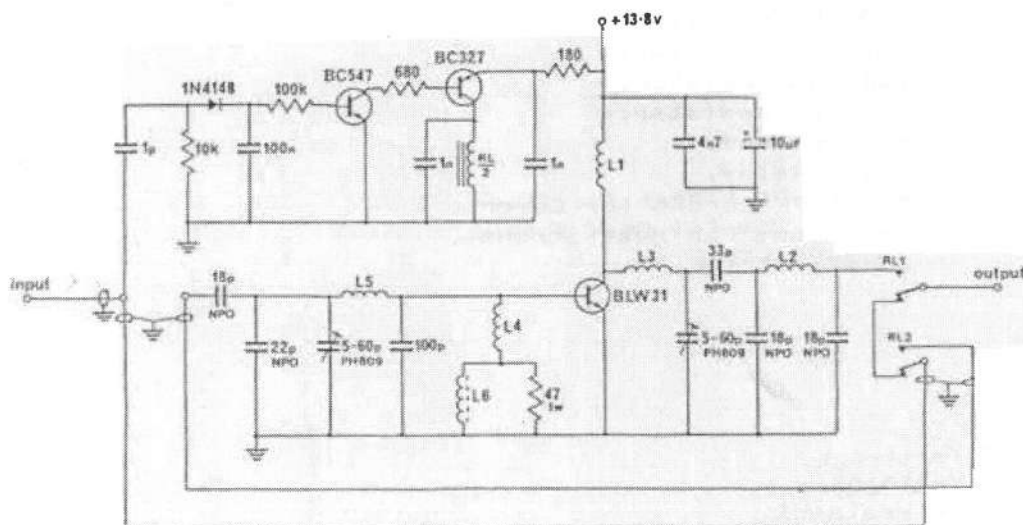

PARTS LIST.

Bag 1

1	PA1 PC Board.
1	Fuse Holder.
200mm	Teflon Coax.
600mm	153 Auto Cable Twin
1	Grommet
4	Small Feet.
1	5 amp Fuse.
1	Length .8mm Wire.
1	Length .6mm Wire.

Bag 2.

1	BLW31 Transistor.
1	BC327 Transistor.
1	BC547 or BC548 Transistor.
1	1N4148 Diode.
3	18 pf Capacitor.
1	22 pf Capacitor.
1	33 pf Capacitor.
1	100pf Capacitor.
1	1 pf Capacitor.
1	.1 mf Capacitor.
2	1 nfd Capacitor.
1	4.7nf Capacitor.
1	10Mfd Capacitor.
2	5-60 pf Trimmer Capacitors.
1	47 ohm 1 Watt Resistor.
1	180 ohm Resistor.
1	680 ohm Resistor.
1	10K ohm Resistor.
1	100Kohm Resistor.
1	6 Hole Bead.
	RY12W Relay.
2	Small PK Screws for Cover.
4	3mm x 6mm Pan Head Screws.
30mm	Copper Strip.

Packed in Box

Bag No 1.
Bag No 2.
Finned Heatsink.
Cover for Heatsink.
Set of Instructions.